

DESCRIPTION SWEEP ELBOW		
CLIENT SPE		
MATERIAL SEE NOTES		
FINISH SEE NOTES	SCALE NONE	JOB
SKETCH STOCKED SWEEPS	BY ABJ	DATE 01/28/02

STOCKED SWEEPS (SHEET 1 OF 2)

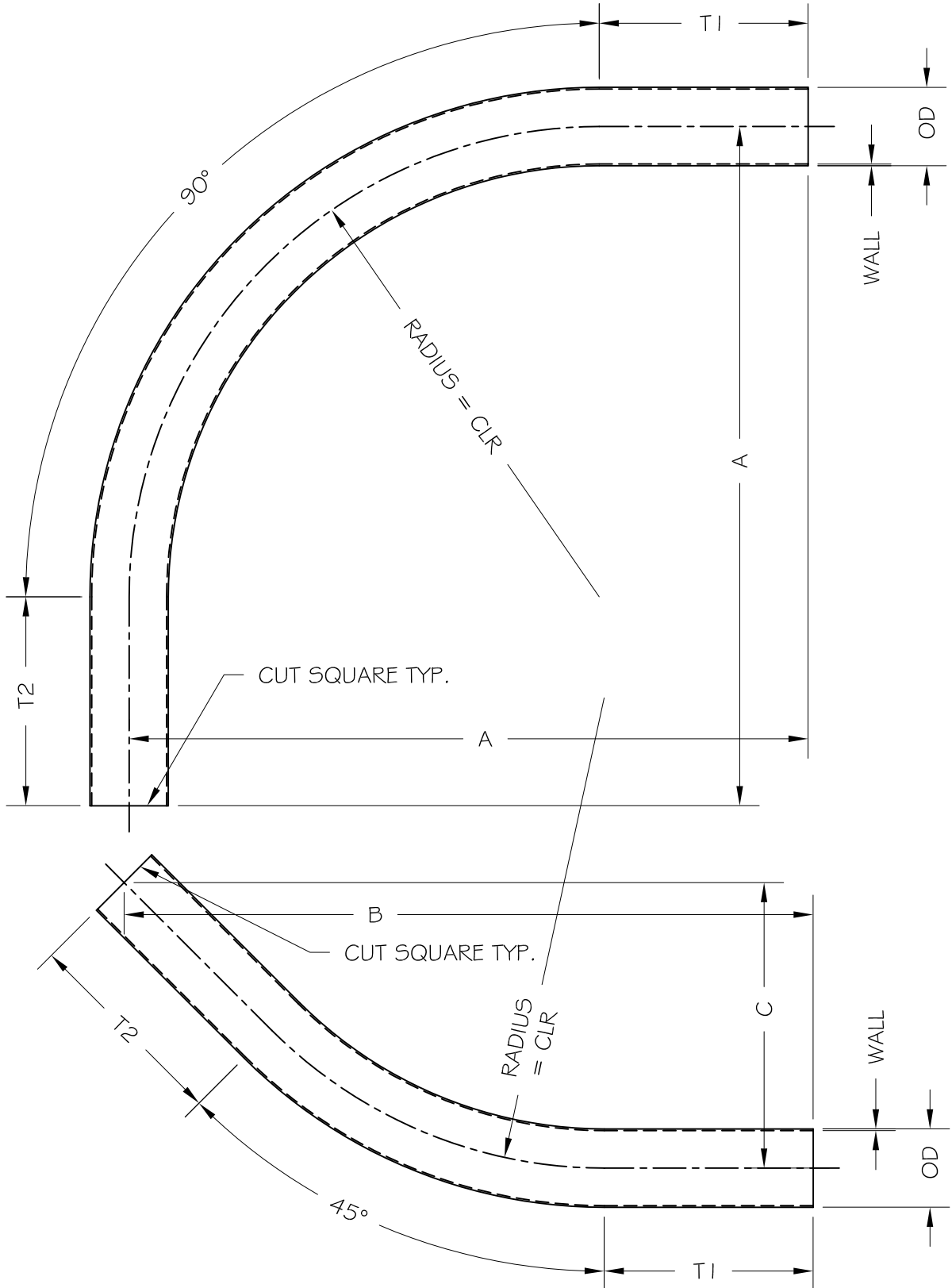

sterling

Process Engineering and Services, Inc.

333 McCormick Blvd. ↔ Columbus, Ohio 43213-1526
 (614) 868-5151 ↔ FAX (614) 868-5152 ↔ sales@sterlingpe.com

DESCRIPTION SWEEP ELBOW			
CLIENT SPE			
MATERIAL SEE NOTES			
FINISH SEE NOTES	SCALE NONE	JOB	
SKETCH STOCKED SWEEPS	BY ABJ	DATE 01/28/02	

STOCKED SWEEPS (SHEET 2 OF 2)

OD	WALL	MIN. CLR
1.5"*	0.065"	-
2"*	0.065"	-
2.5"*	0.065"	18"
3"*	0.065"	18"
4"*	0.083"	24"
6"	0.083"	24"

STD. DIM*	12" CLR*	18" CLR*	24" CLR*	36" CLR*	48" CLR*
T1 & T2*	8"	8"	8"	8"	8"
A*	20"	26"	32"	44"	56"
B*	22.142"	26.385"	30.627"	39.113"	47.598"
C*	9.172"	10.929"	12.686"	16.201"	19.716"

- NOTE: 1) SWEEPS WITH LESS THAN MINIMUM CLR HAVE WRINKLED INNER AND OUTER BEND SURFACES.
 2) SWEEPS WITH OTHER DIMENSIONS MAY BE AVAILABLE.
 3) SWEEPS FURNISHED WITH OTHER T1 & T2 DIMENSIONS AND WITH END FITTINGS IF REQUESTED.

SWEEP PART NUMBER

SWS6309018080807

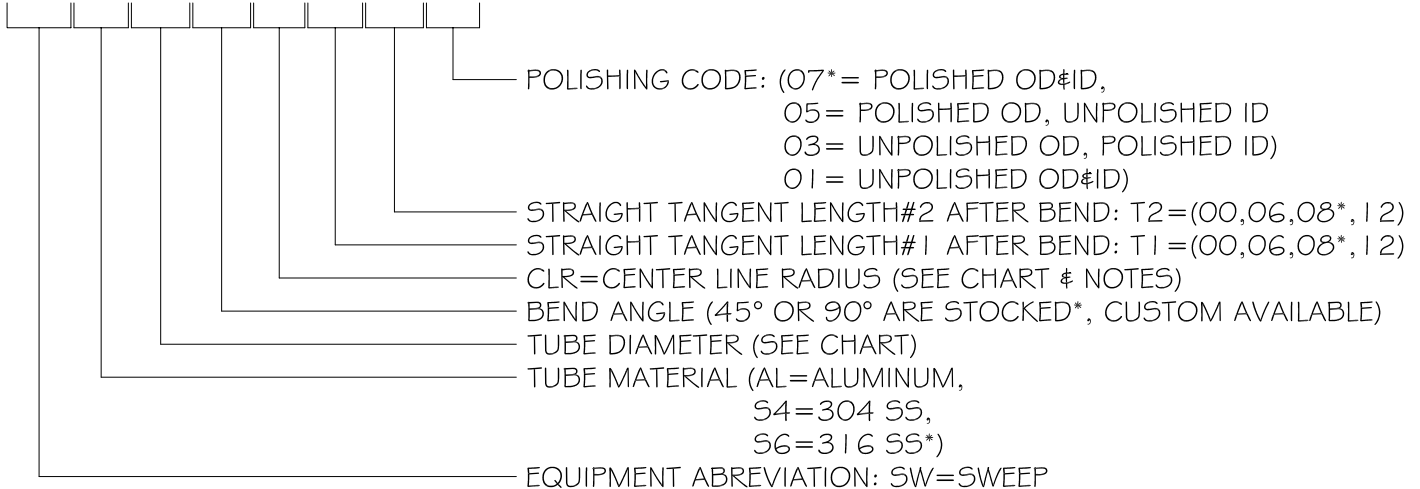

* DENOTES STOCKED SWEEP